

# CTX41727T-DS-43 | E14F10P52

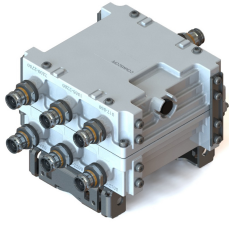

Twin Triplexer 380-960/1695-2200/2300- 2700, DC-sense with 4.3-10 connectors

- BTS-to-feeder and feeder-to-antenna application
- Automatic dc switching with dc sense
- New 4.3-10 connectors for improved PIM performance and size reduction
- DC Load Sense in Feeder-to-Antenna applications
- Convertible mounting brackets
- Stackable in multiples with included hardware

## Product Classification

**Product Type** Triplexer

## General Specifications

**Product Family** CTX41727

**Color** Gray

**Common Port Label** COMM

**Modularity** 2-Twin

**Mounting** Pole | Wall

**Mounting Pipe Hardware** Band clamps (2)

**RF Connector Interface** 4.3-10 Female

**RF Connector Interface Body Style** Long neck

## Dimensions

**Height** 160 mm | 6.299 in

**Width** 165 mm | 6.496 in

**Depth** 108 mm | 4.252 in

**Ground Screw Diameter** 6 mm | 0.236 in

**Mounting Pipe Diameter Range** 42.6–122 mm

## Outline Drawing

# CTX41727T-DS-43 | E14F10P52

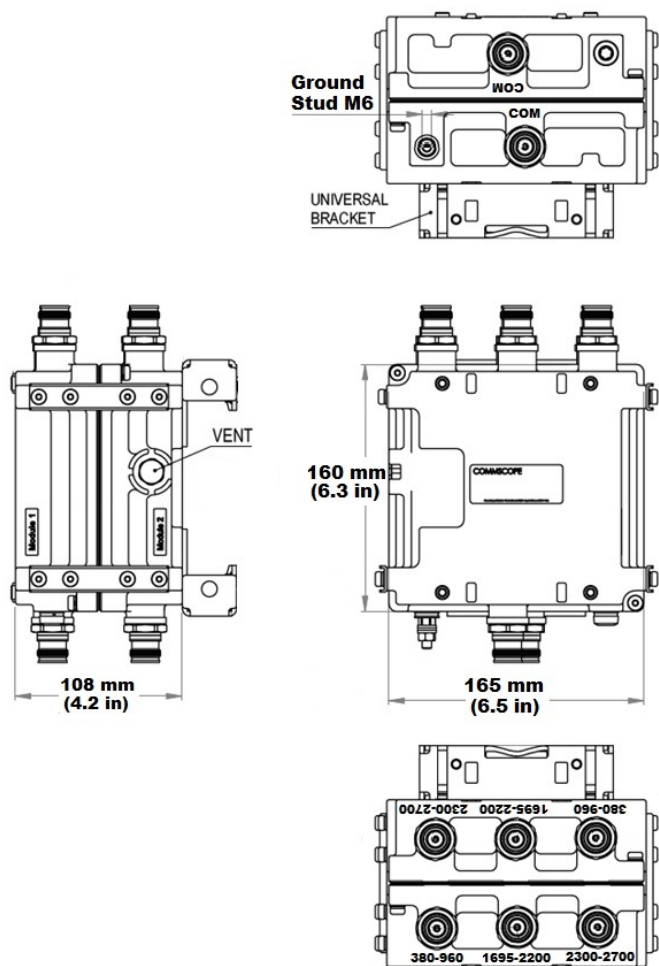

## Electrical Specifications

<b>Impedance</b>	50 ohm
<b>License Band, Band Pass</b>	APT 700   AWS 1700   CEL 850   CEL 900   DCS 1800   EDD 800   IMT 2100   IMT 2600   LMR 750   LMR 800   LMR 900   PCS 1900   USA 700   USA 750   WCS 2300

## Electrical Specifications, dc Power/Alarm

<b>dc/AISG Pass-through Method</b>	Auto sensing
<b>dc/AISG Pass-through Path</b>	See logic table
<b>Lightning Surge Current</b>	5 kA
<b>Lightning Surge Current Waveform</b>	8/20 waveform
<b>Voltage</b>	7–32 Vdc

# CTX41727T-DS-43 | E14F10P52

## Electrical Specifications

<b>Sub-module</b>	<b>1   2</b>	<b>1   2</b>	<b>1   2</b>
<b>Branch</b>	1	2	3
<b>Port Designation</b>	380-960	1695-2200	2300-2700
<b>License Band</b>	CEL 850, Band Pass CEL 900, Band Pass USA 700, Band Pass USA 750, Band Pass	AWS 1700, Band Pass DCS 1800, Band Pass IMT 2100, Band Pass PCS 1900, Band Pass	IMT 2600, Band Pass WCS 2300, Band Pass

## Electrical Specifications, Band Pass

<b>Frequency Range, MHz</b>	<b>380-960</b>	<b>1695-2200</b>	<b>2300-2700</b>
<b>Insertion Loss, typical, dB</b>	0.1	0.2	0.2
<b>Total Group Delay, maximum, ns</b>	20	25	25
<b>Return Loss, typical, dB</b>	20	20	20
<b>Isolation, minimum, dB</b>	50	50	50
<b>Input Power, RMS, maximum, W</b>	200	200	200
<b>Input Power, PEP, maximum, W</b>	2000	2000	2000
<b>3rd Order PIM, maximum, dBc</b>	-155	-155	-155
<b>3rd Order PIM Test Method</b>	Two +43 dBm carriers	Two +43 dBm carriers	Two +43 dBm carriers

## Block Diagram

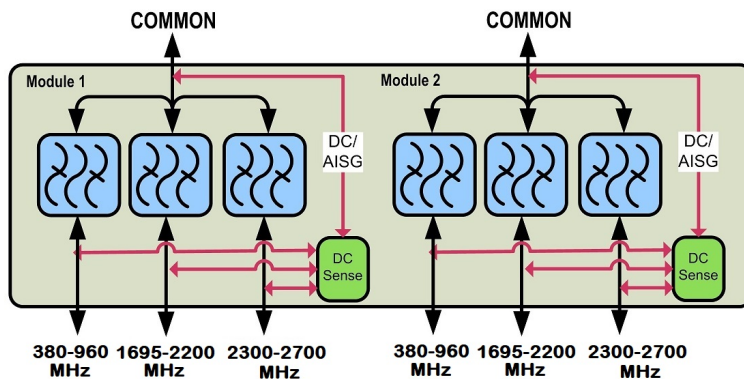

## Logic Table

# CTX41727T-DS-43 | E14F10P52

Combining Mode Operation (Bottom)				
PORT 1 380-960	PORT 2 1695-2200	PORT 3 2300-2700	COMMON	
RF Ports Input Voltage				DC/AISG Path Selection
Any*	Any*	$7 \leq V \leq 30$	<7	380-960 MHz "OFF" 1695-2200 MHz "OFF" 2300-2700MHz "ON"
$7 \leq V \leq 30$	Any*	<7	<7	380-960 MHz "ON" 1695-2200 MHz "OFF" 2300-2700MHz "OFF"
<7	$7 \leq V \leq 30$	<7	<7	380-960 MHz "OFF" 1695-2200 MHz "ON" 2300-2700MHz "OFF"
<7	<7	<7	<7	ALL PORTS OFF

DC/AISG PORT Priority
PORT 3 [Highest]
PORT 1
PORT 2 [Lowest]

\* Any DC voltage applied in the ON (7-30V) or OFF (< 7V) ranges  
 Note: When two or more DC/AISG are available, port with higher priority is bypassed to common

Splitting Mode Operation (Tower Top)				
RF Ports Impedance DC (Load Sense)				
PORT 1 380-960	PORT 2 1695-2200	PORT 3 2300-2700	COMMON	DC/AISG Path Selection
Short	Short	Short	$7 \leq V \leq 30$	ALL PORTS OFF
Open/ Load	Open/ Load	Open/ Load	$7 \leq V \leq 30$	ALL PORTS ON
One or more port(s) are Open/ Load			$7 \leq V \leq 30$	DC/AISG will be passed to ALL Open/Load port(s)

Note: In this mode DC/AISG will be passed to all detected ports and blocked at shortened ones

## Mechanical Specifications

- Wind Loading @ Velocity, frontal** 36.0 N @ 150 km/h (8.1 lbf @ 150 km/h)
- Wind Loading @ Velocity, lateral** 17.0 N @ 150 km/h (3.8 lbf @ 150 km/h)

## Environmental Specifications

- Operating Temperature** -40 °C to +65 °C (-40 °F to +149 °F)
- Relative Humidity** Up to 100%
- Corrosion Test Method** IEC 60068-2-11, 30 days
- Ingress Protection Test Method** IEC 60529:2001, IP67

## Packaging and Weights

- Included** Mounting hardware
- Volume** 2.8 L
- Weight, without mounting hardware** 4.7 kg | 10.362 lb

## Regulatory Compliance/Certifications

Agency	Classification
CHINA-ROHS	Above maximum concentration value
ROHS	Compliant/Exempted
UK-ROHS	Compliant/Exempted

