

CM-H30-B

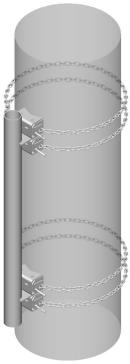

Heavy Duty Chain Mount Kit, 8 ft chain

Product Classification

Product Type Chain mount kit

General Specifications

Chains, quantity 4

Pipe, quantity 0

Sectors, quantity 1

Dimensions

Height 152.4 mm | 6 in

Width 203.2 mm | 8 in

Length 203.2 mm | 8 in

Chain Length 2,400.3 mm | 94.5 in

Mounting Diameter, maximum 762 mm | 30 in

Mounting Diameter, minimum 203.2 mm | 8 in

Pipe Outer Diameter 114.3 mm | 4.5 in

Mounting Circumference, maximum 2,392.68 mm | 94.2 in

Mounting Circumference, minimum 635 mm | 25 in

CM-H30-B

Outline Drawing

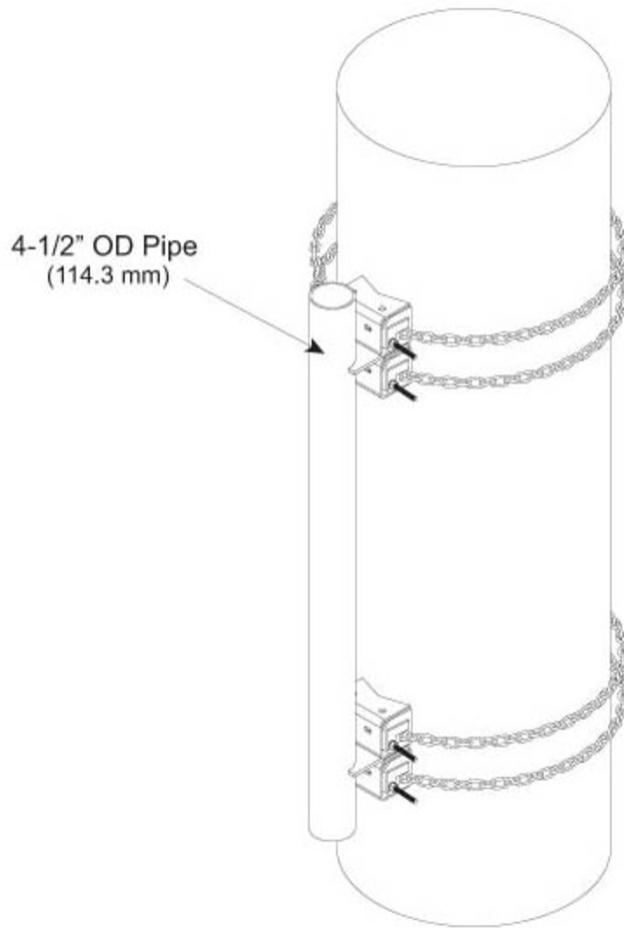

Material Specifications

Material Type Hot dip galvanized steel

Mechanical Specifications

Wind Rating 125 mph (BWS) at 100 ft AGL

Wind Rating Criteria One 8 ft standard microwave antenna, with radome and stiff arm

Wind Rating Test Method TIA/EIA-222

Packaging and Weights

Included Chains

CM-H30-B

Packaging quantity 1
Weight, net 23.6 kg | 52.029 lb

Regulatory Compliance/Certifications

Agency	Classification
ISO 9001:2015	Designed, manufactured and/or distributed under this quality management system

* Footnotes

Wind Rating BWS—Base Wind Speed; FBC—Florida Building Code